

ATLAS 15ZRT



134 kNm



8,5 m



4,4 m



4,7 m



2.550 kg



420°



25,8 kNm



260 bar



100 l/min
ca. 47 kW



65 l/min
ca. 61 kW



150 l/min
ca. 71 kW

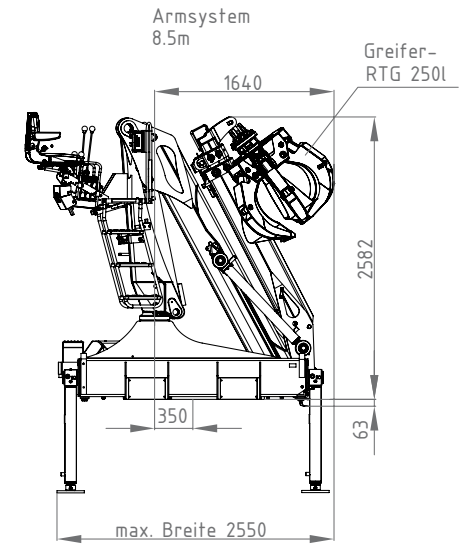
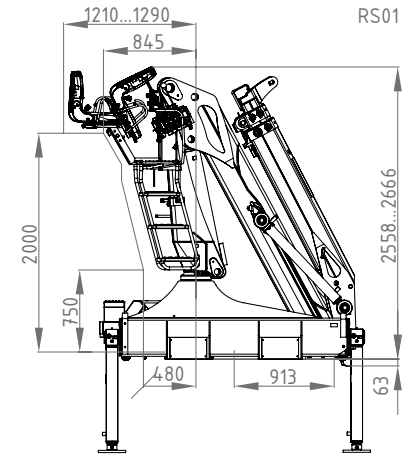
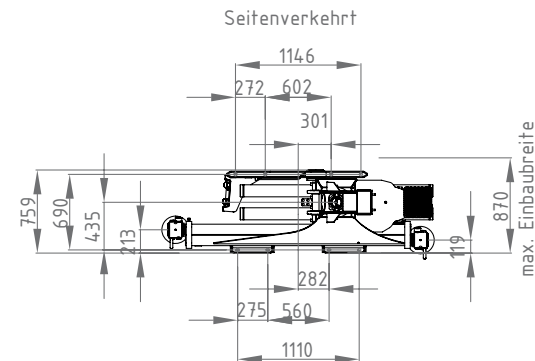
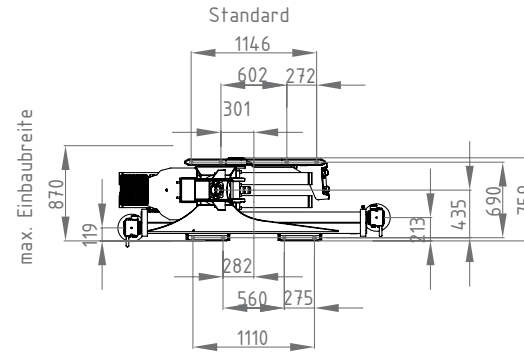
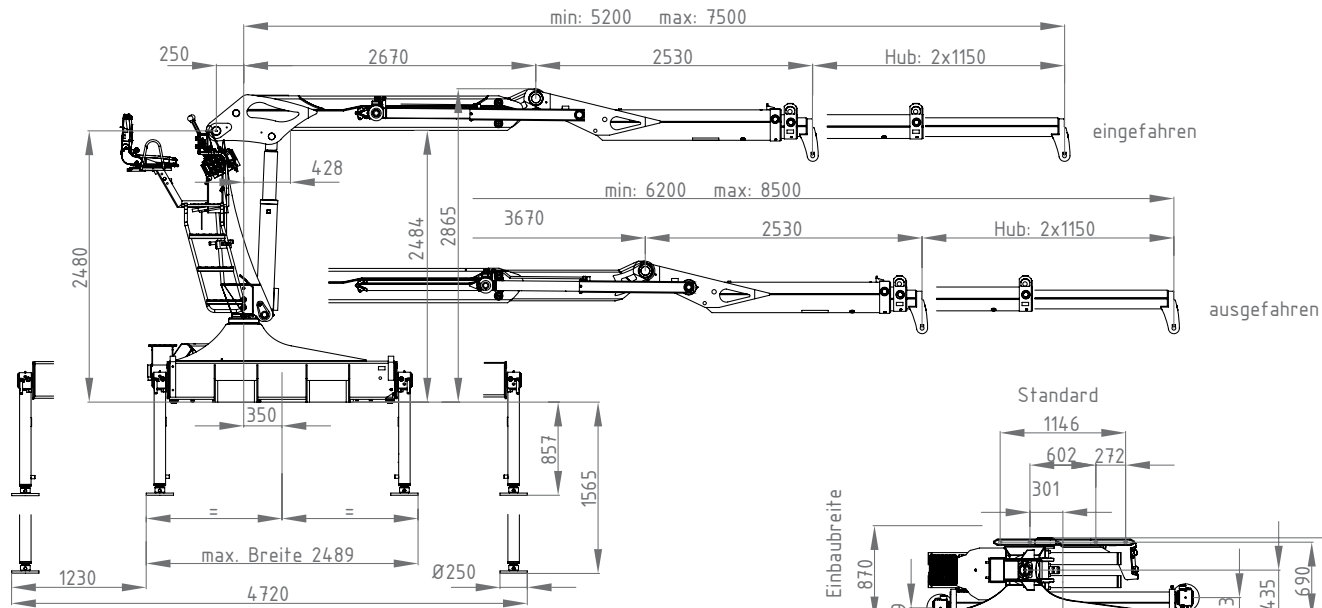

8,5m
Schläuche innen

