

ATLAS 15ZR



134 kNm



7,7 bis
9,4 m



3,2 bis
3,6 m



4,7 m



2.550 kg



420°



25,8 kNm



260 bar



1x
100 l/min
ca. 47 kW



2x
65 l/min
ca. 61 kW



LS
150 l/min
ca. 71 kW

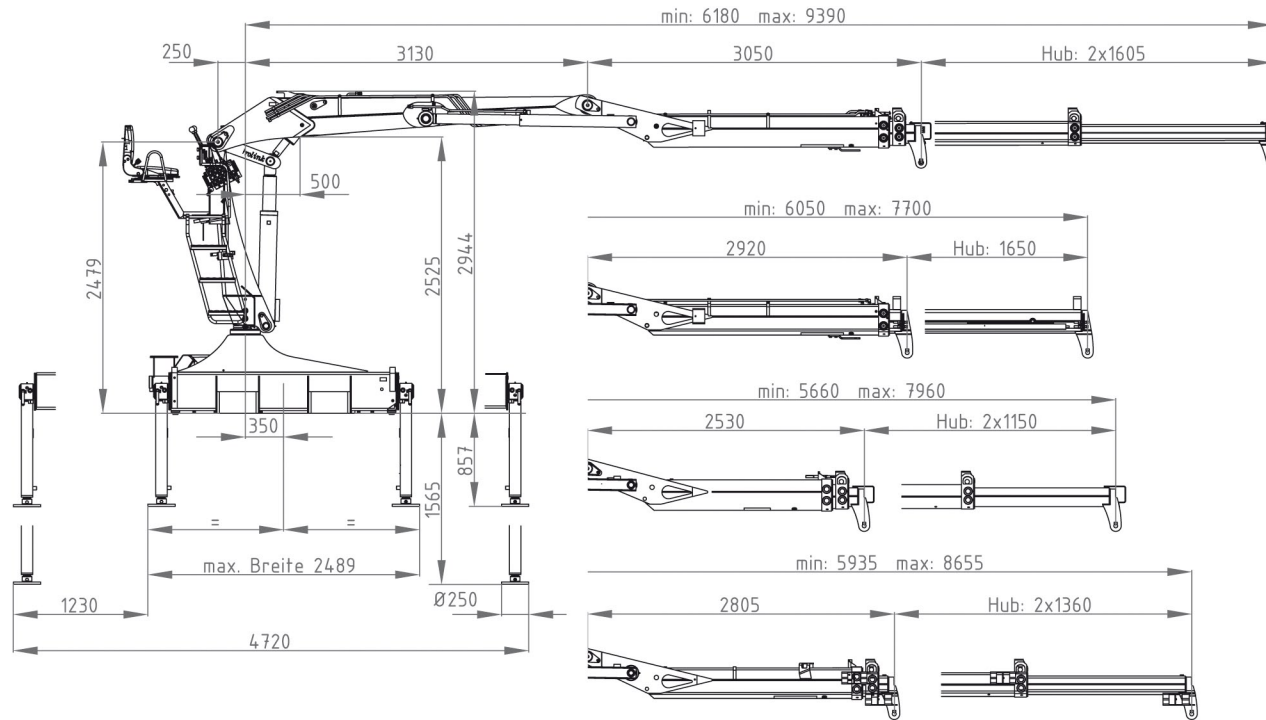

9,4m
Schläuche innen
Schläuche außen

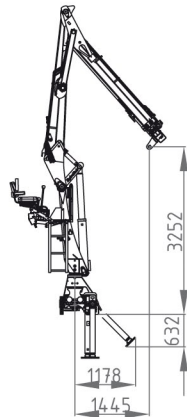

8,65m
Schläuche innen
Schläuche außen

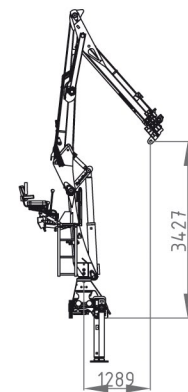

8,0m
Schläuche innen

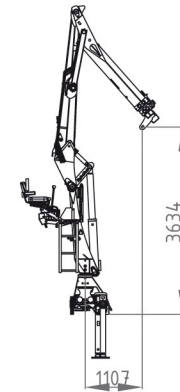

7,7m
Schläuche innen
Schläuche außen

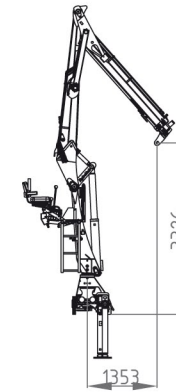

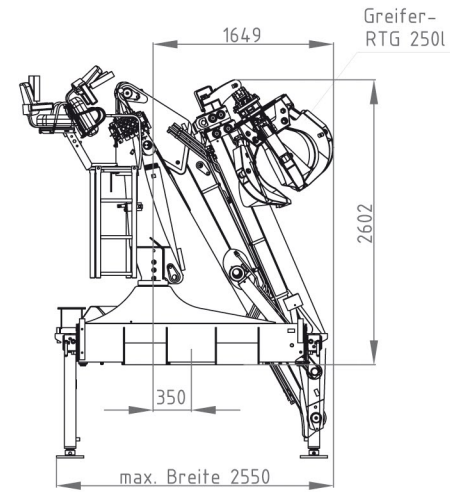
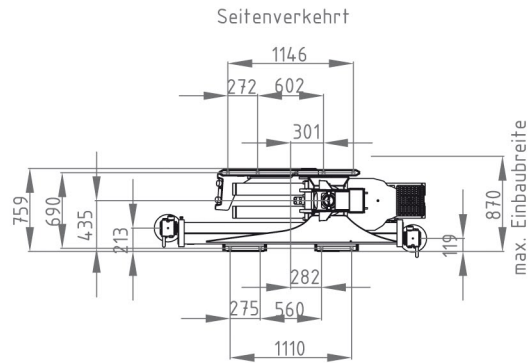
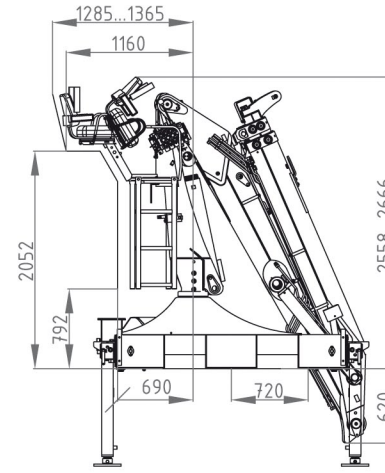
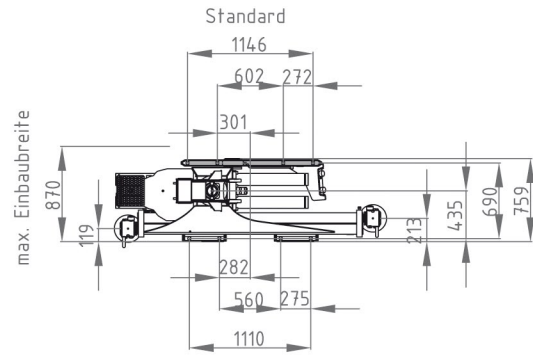

	3m	4m	5m	6m	7m	8m	
7,7m	4200	3245	2610	2230	1820	-	kg
8,0m	4170	3220	2595	2210	1795	-	kg
8,65m	4080	3170	2570	2100	1640	1500	kg
9,4m	4200	3125	2540	2050	1560	1510	kg

