

ATLAS 15LR



136 kNm



7,6 bis
10,1 m

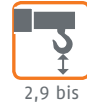

2,9 bis
4,0 m



4,5 m



2.606 kg



405°



31,0 kNm



230 bar



65 l/min
ca. 54 kW



150 l/min
ca. 72 kW

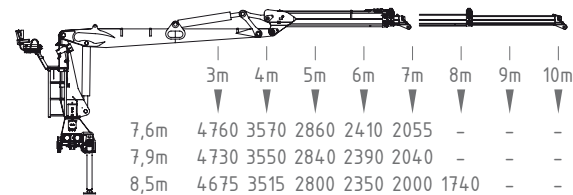
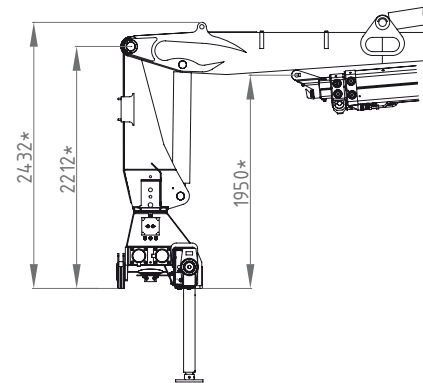
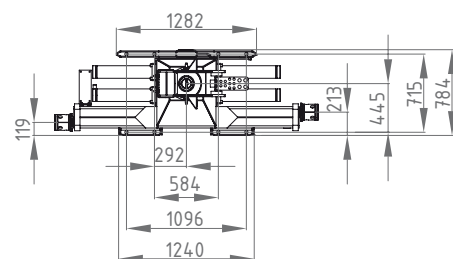
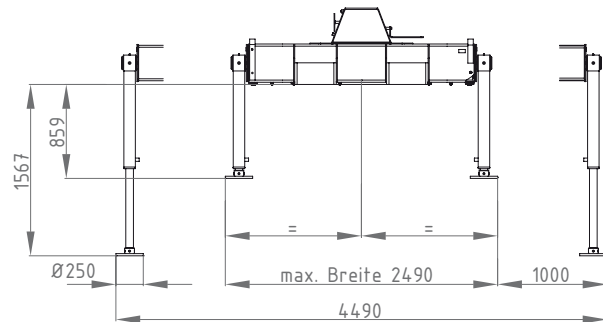
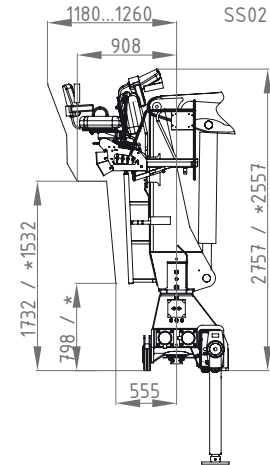
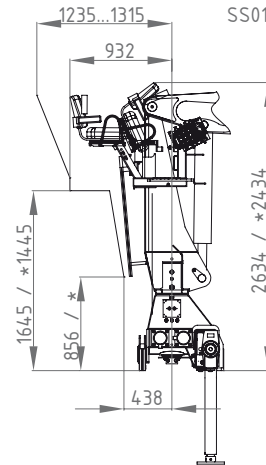
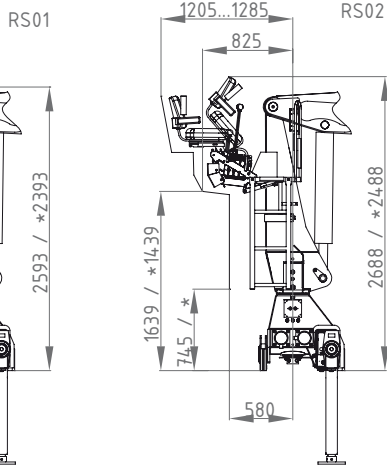
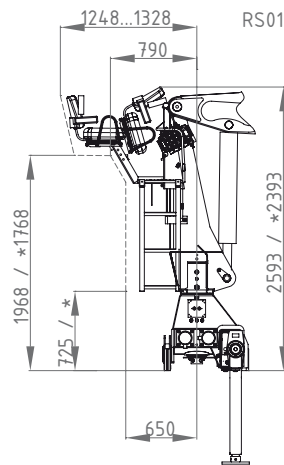

	3m	4m	5m	6m	7m	8m	9m	10m	
7,6m	4760	3570	2860	2410	2055	-	-	-	kg
7,9m	4730	3550	2840	2390	2040	-	-	-	kg
8,5m	4675	3515	2800	2350	2000	1740	-	-	kg
9,3m	4580	3425	2760	2300	1960	1700	1450	-	kg
9,6m	4560	3406	2750	2280	1940	1680	1430	-	kg
10,1m	4500	3375	2700	2250	1910	1650	1400	1290	kg

*Bemassungen mit verkürzter Kransäule

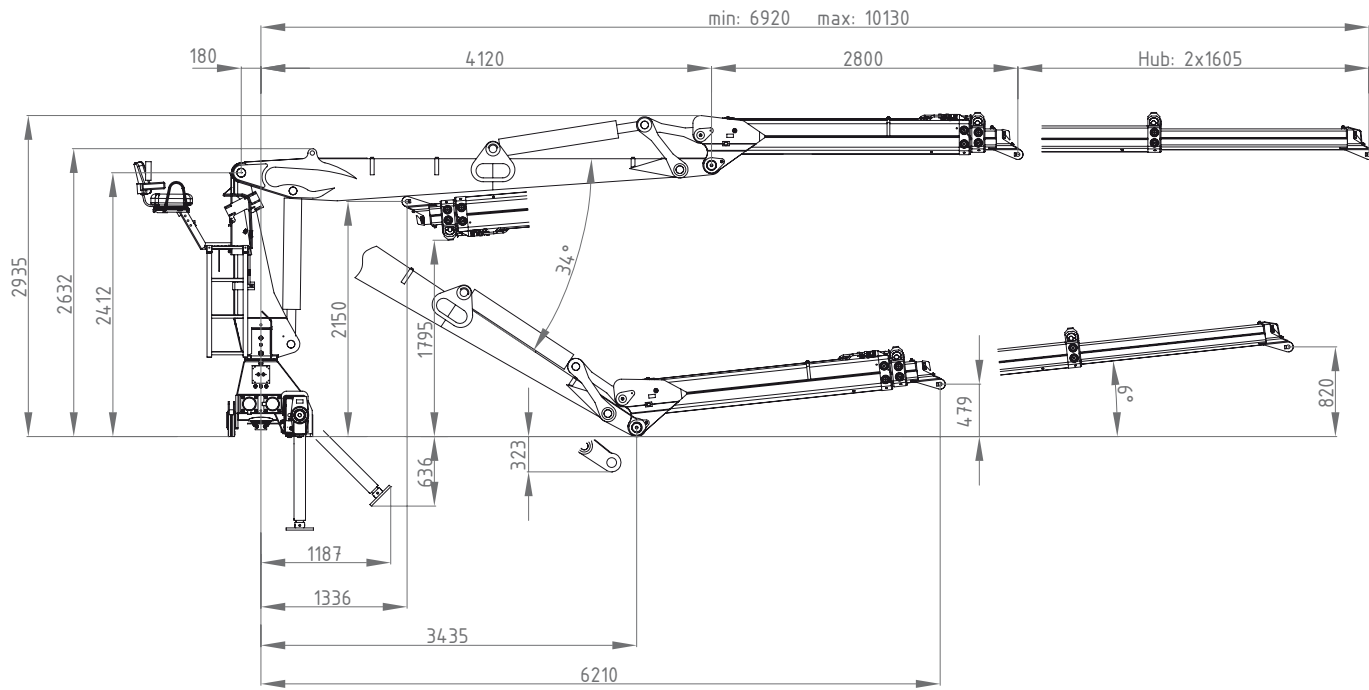

10,1m
Schläuche innen

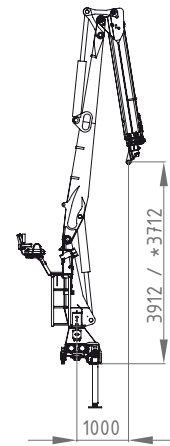

9,6m
Schläuche innen

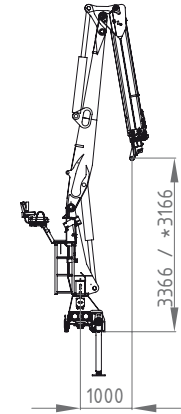

9,3m
Schläuche innen

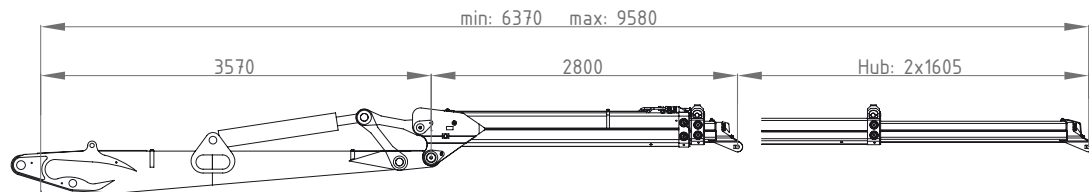
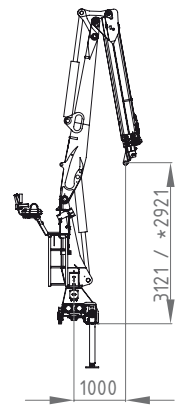

8,5m
Schläuche innen

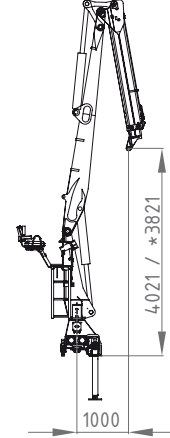

7,9m
Schläuche innen

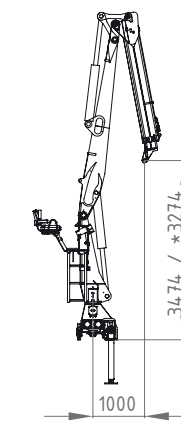

7,6m
Schläuche innen

